



VNQ660SP

QUAD CHANNEL HIGH SIDE SOLID STATE RELAY

TYPE	R _{DS(on)}	I _{OUT}	V _{CC}
VNQ660SP	50mΩ (*)	6A	36 V

(*) Per each channel

- OUTPUT CURRENT PER CHANNEL: 6A
- CMOS COMPATIBLE INPUTS
- OPEN LOAD DETECTION (OFF STATE)
- UNDERVOLTAGE & OVERVOLTAGE SHUT-DOWN
- OVERVOLTAGE CLAMP
- THERMAL SHUT-DOWN
- CURRENT LIMITATION
- VERY LOW STAND-BY POWER DISSIPATION
- PROTECTION AGAINST:
 - LOSS OF GROUND & LOSS OF V_{CC}
- REVERSE BATTERY PROTECTION (**)

DESCRIPTION

The VNQ660SP is a monolithic device made by

ABSOLUTE MAXIMUM RATING

Symbol	Parameter	Value	Unit
V _{CC}	Supply voltage (continuous)	41	V
-V _{CC}	Reverse supply voltage (continuous)	-0.3	V
I _{OUT}	Output current (continuous), per each channel	Internally limited	A
I _R	Reverse output current (continuous), per each channel	-15	A
I _{IN}	Input current	+/- 10	mA
I _{STAT}	Status current	+/- 10	mA
I _{GND}	Ground current at T _C ≤25°C (continuous)	-200	mA
V _{ESD}	Electrostatic Discharge (Human Body Model: R=1.5KΩ; C=100pF)		
	- INPUT	4000	V
	- STATUS	4000	V
	- OUTPUT	5000	V
	- V _{CC}	5000	V
E _{MAX}	Maximum Switching Energy (L=1.46mH; R _L =0Ω; V _{bat} =13.5V; T _{jstart} =150°C; I _L =10A)	101	mJ
P _{tot}	Power dissipation at T _C =25°C	113.6	W
T _j	Junction operating temperature	-40 to 150	°C
T _{stg}	Storage temperature	-65 to 150	°C
E _C	Non repetitive clamping energy at T _C =25°C	150	mJ

(**) See application schematic at page 8

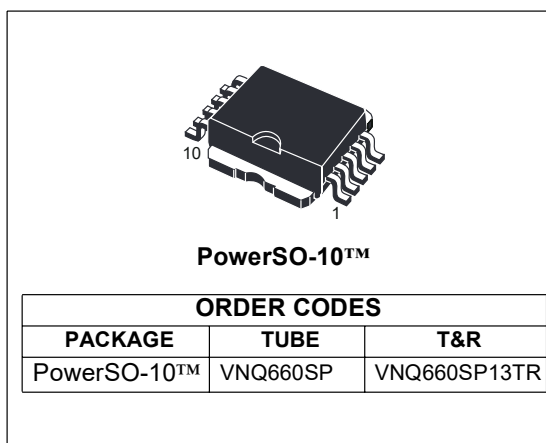

using STMicroelectronics VIPower M0-3 Technology, intended for driving resistive or inductive loads with one side connected to ground. This device has four independent channels. Built-in thermal shut down and output current limitation protect the chip from over temperature and short circuit.

BLOCK DIAGRAM

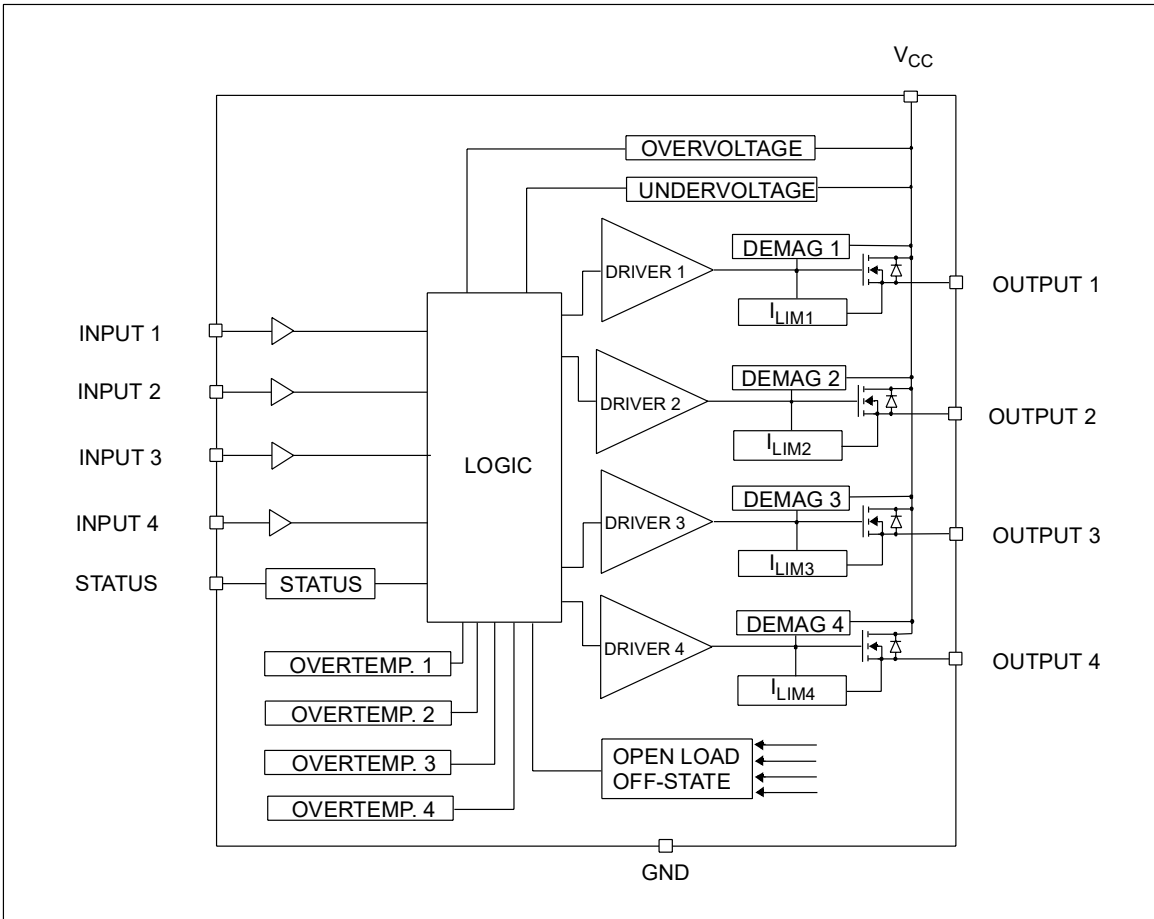

CURRENT AND VOLTAGE CONVENTIONS

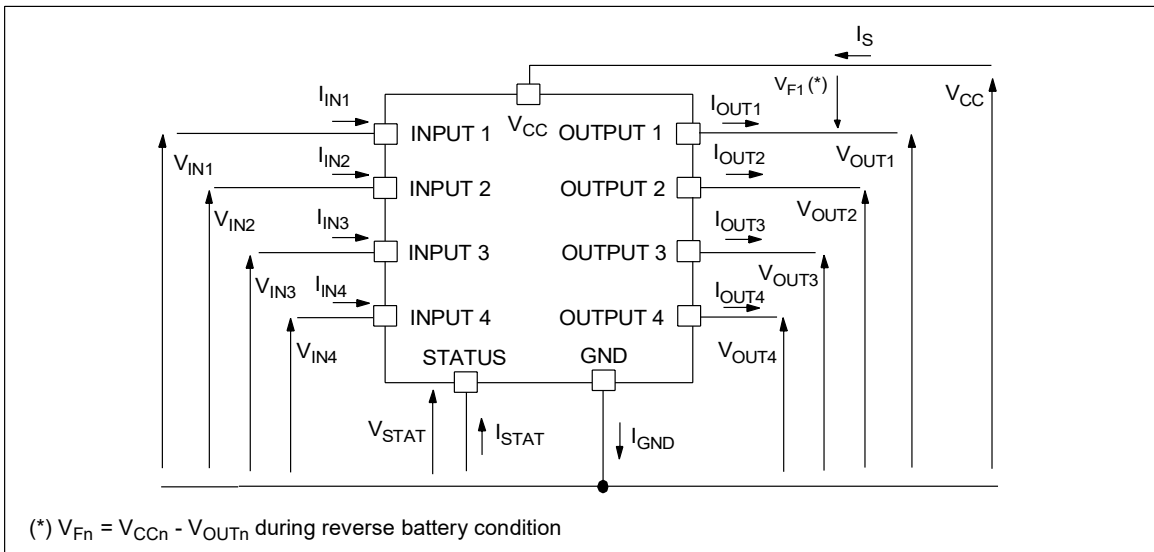

CONFIGURATION DIAGRAM (TOP VIEW) & SUGGESTED CONNECTIONS FOR UNUSED AND N.C. PINS

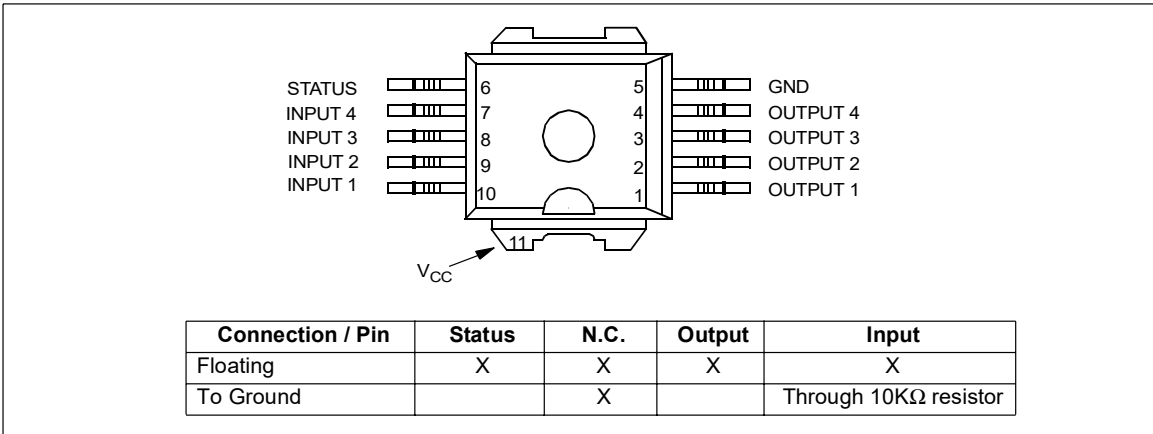

THERMAL DATA

Symbol	Parameter	Value		Unit
$R_{thj-case}$	Thermal resistance junction-case (MAX) (all channels on)	1.1 ⁽¹⁾	52 ⁽²⁾	°C/W
$R_{thj-amb}$	Thermal resistance junction-ambient (MAX)	51.1 ⁽¹⁾	33 ⁽²⁾	°C/W

(1) When mounted on a standard single-sided FR-4 board with 1cm² of Cu (at least 35 μm thick). Horizontal mounting and no artificial air flow.
 (2) When mounted on a standard single-sided FR-4 board with 6cm² of Cu (at least 35 μm thick). Horizontal mounting and no artificial air flow.

ELECTRICAL CHARACTERISTICS ($V_{CC}=6V$ up to 24V; $-40^{\circ}C < T_j < 150^{\circ}C$ unless otherwise specified)

POWER (per each channel)

Symbol	Parameter	Test Conditions	Min	Typ	Max	Unit
$V_{CC}^{(**)}$	Operating supply voltage		6	13	36	V
$V_{USD}^{(**)}$	Undervoltage shutdown		3.5	4.6	6	V
$V_{UVhyst}^{(**)}$	Undervoltage hysteresis		0.2		1	V
$V_{OV}^{(**)}$	Overvoltage shutdown		36			V
$V_{OVhyst}^{(**)}$	Overvoltage hysteresis		0.25			V
$I_S^{(**)}$	Supply current	Off state; Input=0V; $V_{CC}=13.5V$		12	40	A
		Off state; Input=0V; $V_{CC}=13.5V$		12	25	A
		$T_j=25^{\circ}C$				
		On state Input=3.25V; $9V < V_{CC} < 18V$		6	12	mA
$R_{DS(on)}$	On state resistance	$I_{OUT}=1A$; $T_j=25^{\circ}C$; $9V < V_{CC} < 18V$		40	50	mΩ
		$I_{OUT}=1A$; $T_j=150^{\circ}C$; $9V < V_{CC} < 18V$		85	100	mΩ
		$I_{OUT}=1A$; $V_{CC}=6V$			130	mΩ
$I_{L(off1)}$	Off state output current	$V_{IN}=V_{OUT}=0V$	0		50	A
$I_{L(off2)}$	Off State Output Current	$V_{IN}=0V$; $V_{OUT}=3.5V$	-75		0	A
$I_{L(off3)}$	Off State Output Current	$V_{IN}=V_{OUT}=0V$; $V_{CC}=13V$; $T_j=125^{\circ}C$			5	A
$I_{L(off4)}$	Off State Output Current	$V_{IN}=V_{OUT}=0V$; $V_{CC}=13V$; $T_j=25^{\circ}C$			3	A

(**) Per device.

VCC - OUTPUT DIODE

Symbol	Parameter	Test Conditions	Min	Typ	Max	Unit
V_F	Forward on Voltage	$-I_{OUT}=1.6A$; $T_j=150^{\circ}C$			0.6	V

ELECTRICAL CHARACTERISTICS (continued)SWITCHING ($V_{CC}=13V$)

Symbol	Parameter	Test Conditions	Min	Typ	Max	Unit
$t_{d(on)}$	Turn-on delay time	$R_L=13\Omega$ channels 1,2,3,4		40	70	s
$t_{d(off)}$	Turn-off delay time	$R_L=13\Omega$ channels 1,2,3,4		40	140	s
$dV_{OUT}/dt_{(on)}$	Turn-on voltage slope	$R_L=13\Omega$ channels 1,2,3,4		See relative diagram		V/ s
$dV_{OUT}/dt_{(off)}$	Turn-off voltage slope	$R_L=13\Omega$ channels 1,2,3,4		See relative diagram		V/ s

PROTECTIONS (per each channel) (see note 1)

Symbol	Parameter	Test Conditions	Min	Typ	Max	Unit
T_{TSD}	Shutdown temperature		150	170	200	$^{\circ}C$
T_R	Reset temperature		135			$^{\circ}C$
T_{hyst}	Thermal hysteresis		7	15	25	$^{\circ}C$
I_{lim}	DC Short circuit current	$9V < V_{CC} < 36V$ $6V < V_{CC} < 36V$	6	10	18 18	A A
V_{demag}	Turn-off output voltage clamp	$I_{OUT}=2A$; $V_{IN}=0V$; $L=6mH$	$V_{CC}-41$	$V_{CC}-48$	$V_{CC}-55$	V
V_{STAT}	Status low output voltage	$I_{STAT}=1.6mA$			0.5	V
I_{LSTAT}	Status leakage current	Normal operation; $V_{STAT}=5V$			10	A
C_{STAT}	Status pin input capacitance	Normal operation; $V_{STAT}=5V$			25	pF
V_{SCL}	Status clamp voltage	$I_{STAT}=1mA$ $I_{STAT}=-1mA$	6	6.8 -0.7	8	V V

Note 1: To ensure long term reliability under heavy overload or short circuit conditions, protection and related diagnostic signals must be used together with a proper software strategy. If the device is subjected to abnormal conditions, this software must limit the duration and number of activation cycles.

LOGIC INPUT (per each channel)

Symbol	Parameter	Test Conditions	Min	Typ	Max	Unit
V_{IL}	Input Low Level Voltage				1.25	V
V_{IH}	Input High Level Voltage		3.25			V
V_{HYST}	Input Hysteresis Voltage		0.5			V
I_{IH}	Input high level voltage	$V_{IN}=3.25V$			10	A
I_{IL}	Input Current	$V_{IN}=1.25V$	1			A
C_{IN}	Input Capacitance				40	pF
V_{ICL}	Input Clamp Voltage	$I_{IN}=1mA$ $I_{IN}=-1mA$	6	6.8 -0.7	8	V V

OPENLOAD DETECTION (off state) per each channel

Symbol	Parameter	Test Conditions	Min	Typ	Max	Unit
t_{SDL}	Status Delay	(*)			20	s
V_{OL}	Openload Voltage Detection Threshold	$V_{IN}=0V$	1.5	2.5	3.5	V
T_{DOL}	Openload Detection Delay at Turn Off	$V_{CC}=18V$ (*)			300	s

(*) See Figure 1

ELECTRICAL TRANSIENT REQUIREMENTS

ISO T/R 7637/1 Test Pulse	TEST LEVELS				Delays and Impedance
	I	II	III	IV	
1	-25 V	-50 V	-75 V	-100 V	2 ms 10 Ω
2	+25 V	+50 V	+75 V	+100 V	0.2 ms 10 Ω
3a	-25 V	-50 V	-100 V	-150 V	0.1 s 50 Ω
3b	+25 V	+50 V	+75 V	+100 V	0.1 s 50 Ω
4	-4 V	-5 V	-6 V	-7 V	100 ms, 0.01 Ω

ISO T/R 7637/1 Test Pulse	Test Levels Result			
	I	II	III	IV
1	C	C	C	C
2	C	C	C	C
3a	C	C	C	C
3b	C	C	C	C
4	C	C	C	C
5	C	E	E	E

Class	Contents
C	All functions of the device are performed as designed after exposure to disturbance.
E	One or more functions of the device is not performed as designed after exposure and cannot be returned to proper operation without replacing the device.

SWITCHING CHARACTERISTICS

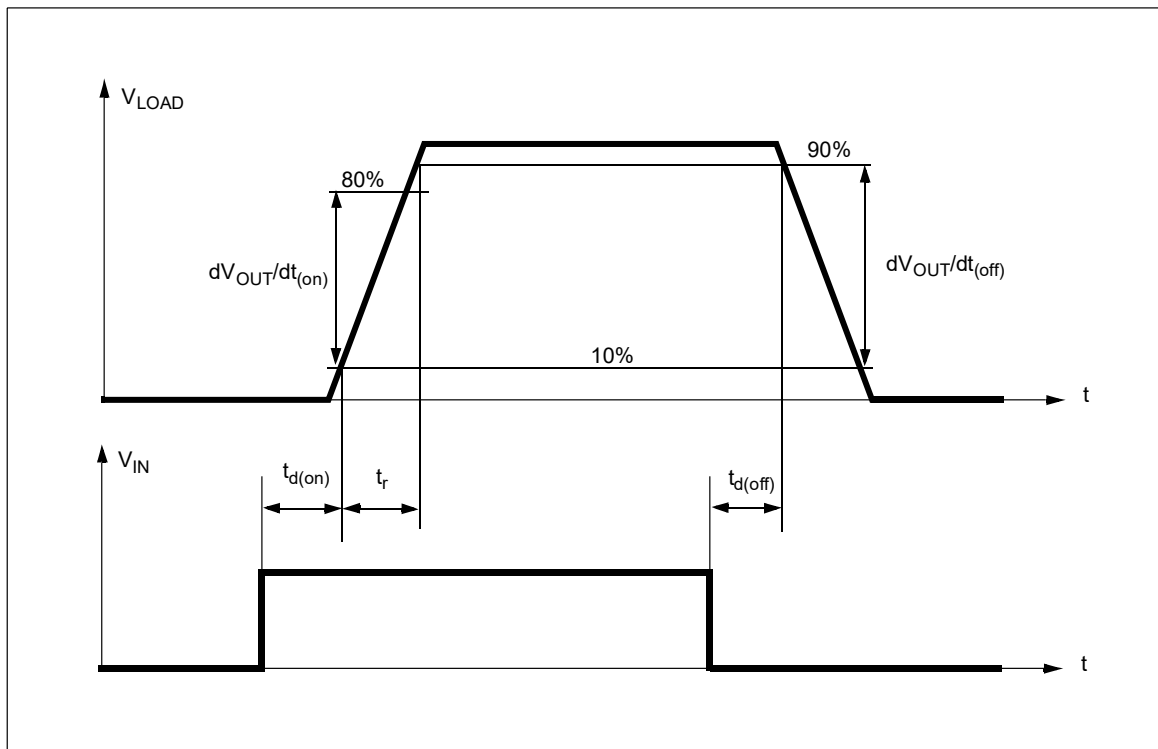

TRUTH TABLE (per each channel)

CONDITIONS	INPUT	OUTPUT	STATUS
Normal Operation	L	L	H
	H	H	H
Current Limitation	L	L	H
	H	X	($T_j < T_{TSD}$) H ($T_j > T_{TSD}$) L
Overtemperature	L	L	H
	H	L	L
Undervoltage	L	L	X
	H	L	X
Overvoltage	L	L	H
	H	L	H
Output Voltage > V_{OL}	L	H	L
	H	H	H
Output Current < I_{OL}	L	L	H
	H	H	L

Figure 1: Status timing waveforms

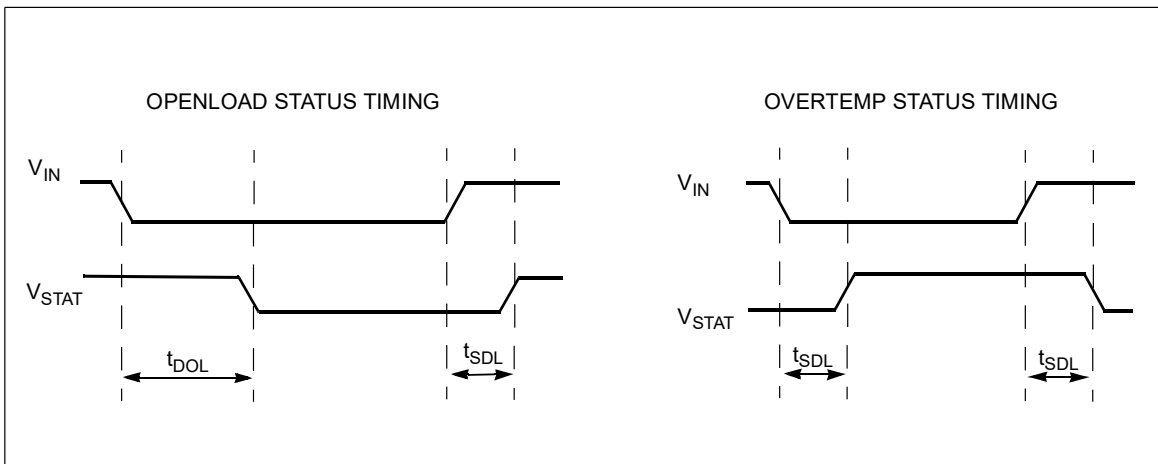
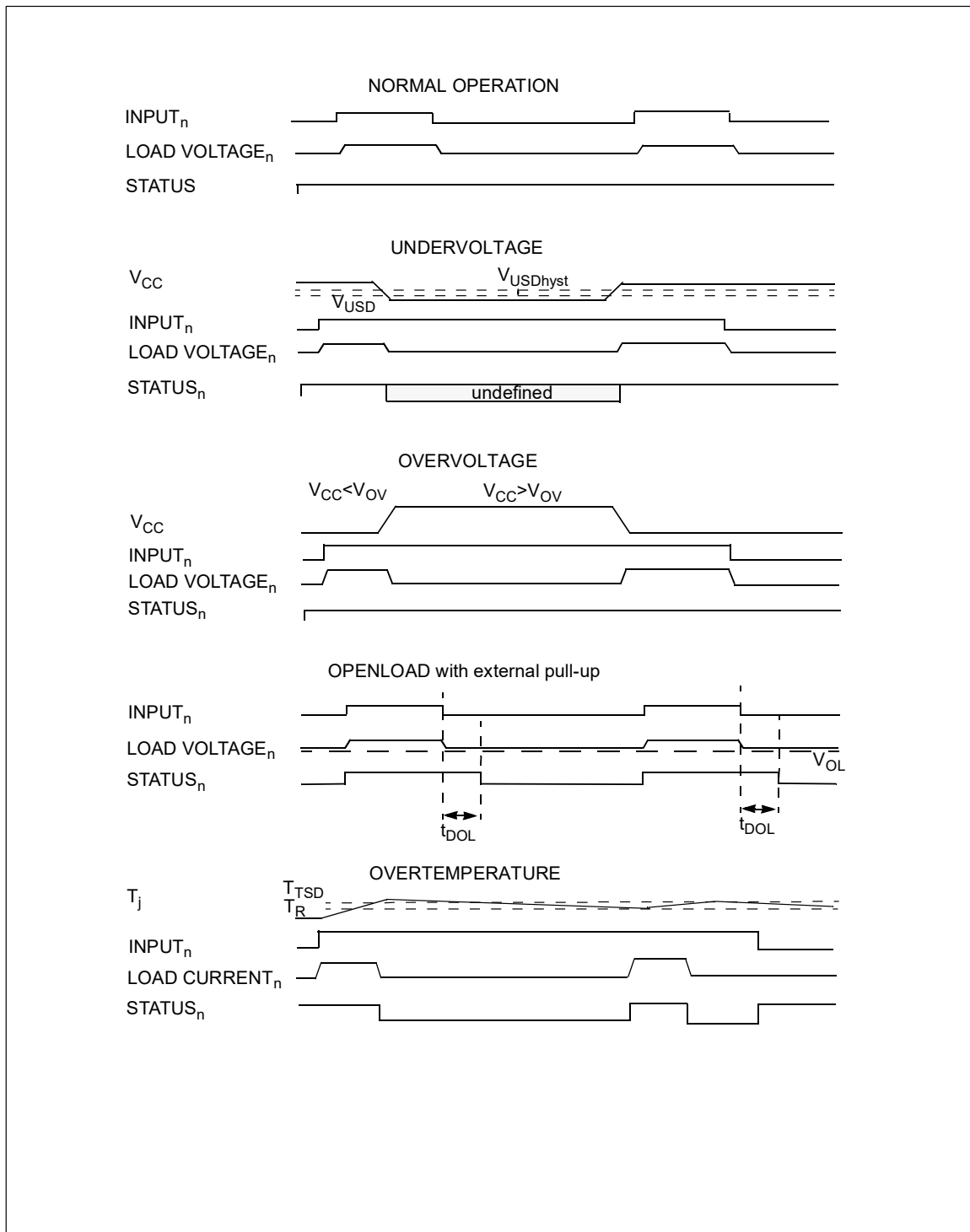
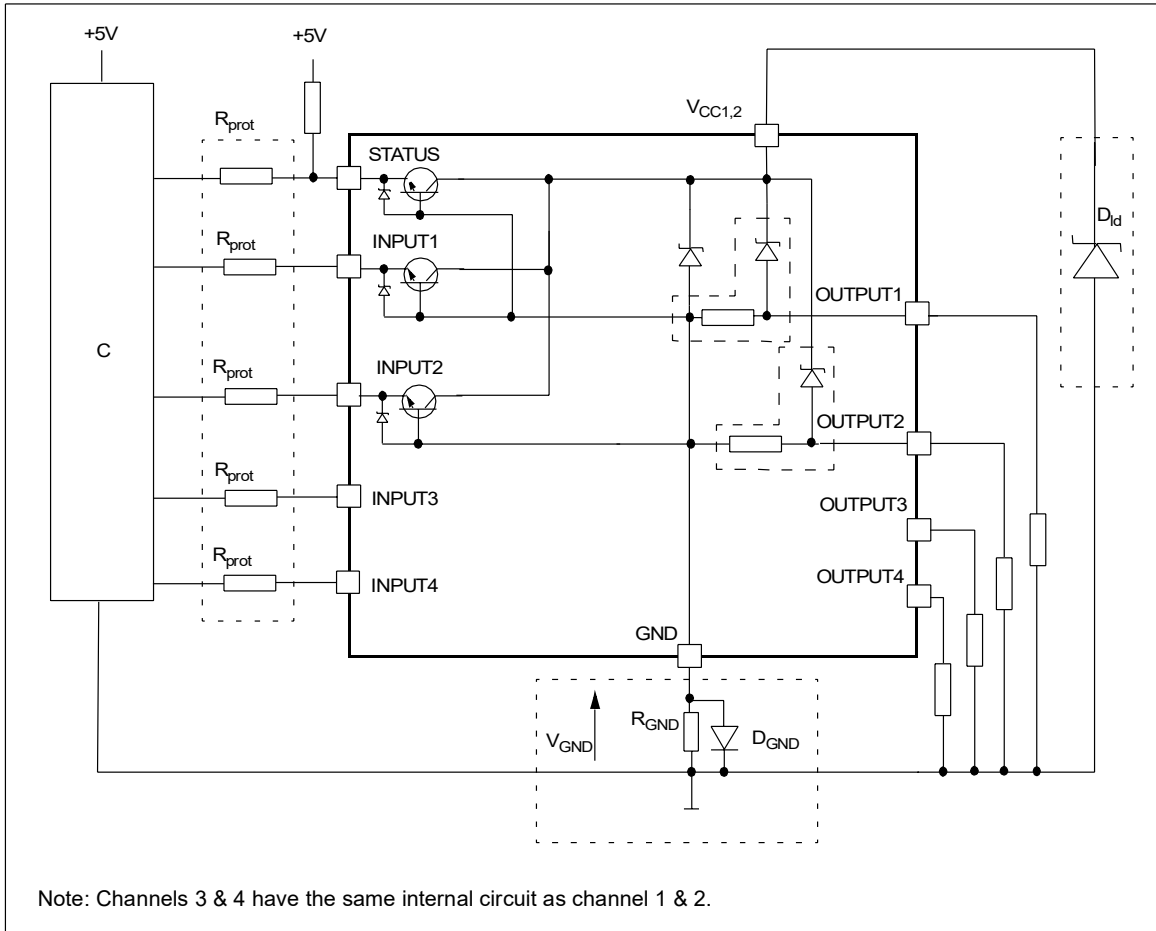

Figure 2: Waveforms



APPLICATION SCHEMATIC



GND PROTECTION NETWORK AGAINST REVERSE BATTERY

Solution 1: Resistor in the ground line (R_{GND} only). This can be used with any type of load.

The following is an indication on how to dimension the R_{GND} resistor.

- 1) $R_{GND} \leq 600mV / (I_{S(on)max})$.
- 2) $R_{GND} \geq (-V_{CC}) / (-I_{GND})$

where $-I_{GND}$ is the DC reverse ground pin current and can be found in the absolute maximum rating section of the device's datasheet.

Power Dissipation in R_{GND} (when $V_{CC} < 0$: during reverse battery situations) is:

$$P_D = (-V_{CC})^2 / R_{GND}$$

This resistor can be shared amongst several different HSD. Please note that the value of this resistor should be calculated with formula (1) where $I_{S(on)max}$ becomes the sum of the maximum on-state currents of the different devices.

Please note that if the microprocessor ground is not common with the device ground then the R_{GND} will

produce a shift ($I_{S(on)max} * R_{GND}$) in the input thresholds and the status output values. This shift will vary depending on how many devices are ON in the case of several high side drivers sharing the same R_{GND} .

If the calculated power dissipation leads to a large resistor or several devices have to share the same resistor then the ST suggests to utilize Solution 2 (see below).

Solution 2: A diode (D_{GND}) in the ground line.

A resistor ($R_{GND} = 1k\Omega$) should be inserted in parallel to D_{GND} if the device will be driving an inductive load.

This small signal diode can be safely shared amongst several different HSD. Also in this case, the presence of the ground network will produce a shift ($\approx 600mV$) in the input threshold and the status output values if the microprocessor ground is not common with the device ground. This shift will not vary if more than one HSD shares the same diode/resistor network.

Series resistor in INPUT and STATUS lines are also required to prevent that, during battery voltage transient, the current exceeds the Absolute Maximum Rating.

Safest configuration for unused INPUT and STATUS pin is to leave them unconnected.

LOAD DUMP PROTECTION

D_{ld} is necessary (Voltage Transient Suppressor) if the load dump peak voltage exceeds V_{CC} max DC rating. The same applies if the device will be subject to transients on the V_{CC} line that are greater than the ones shown in the ISO T/R 7637/1 table.

C I/Os PROTECTION:

If a ground protection network is used and negative transient are present on the V_{CC} line, the control pins will be pulled negative. ST suggests to insert a resistor (R_{prot}) in line to prevent the C I/Os pins to latch-up.

The value of these resistors is a compromise between the leakage current of C and the current required by the HSD I/Os (Input levels compatibility) with the latch-up limit of C I/Os.

$$-V_{CCpeak}/I_{latchup} \leq R_{prot} \leq (V_{OH\ C} - V_{IH} - V_{GND}) / I_{IHmax}$$

Calculation example:

For $V_{CCpeak} = -100V$ and $I_{latchup} \geq 20mA$; $V_{OH\ C} \geq 4.5V$

$$5k\Omega \leq R_{prot} \leq 65k\Omega.$$

Recommended R_{prot} value is 10k Ω .

Off State Output Current

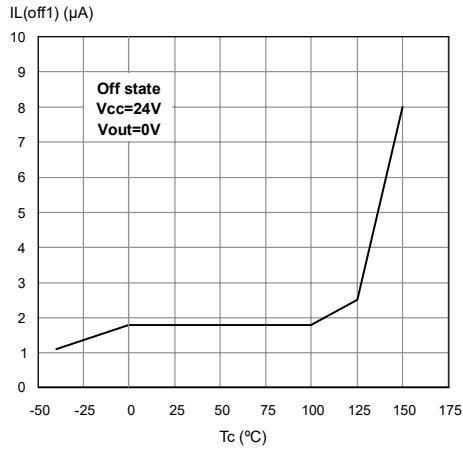

High Level Input Current

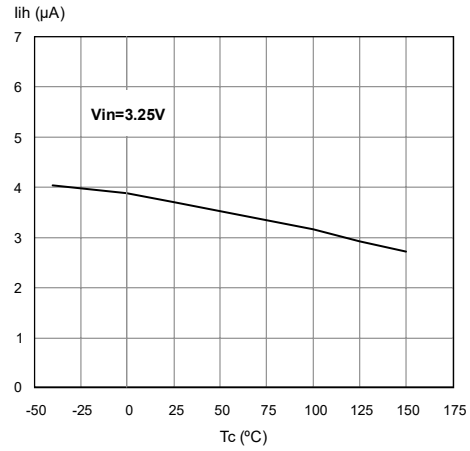

Input Clamp Voltage

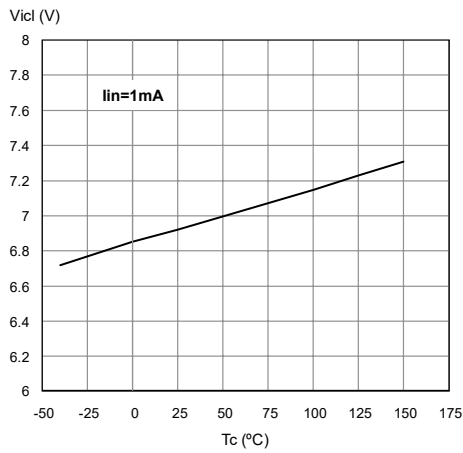

Input High Level

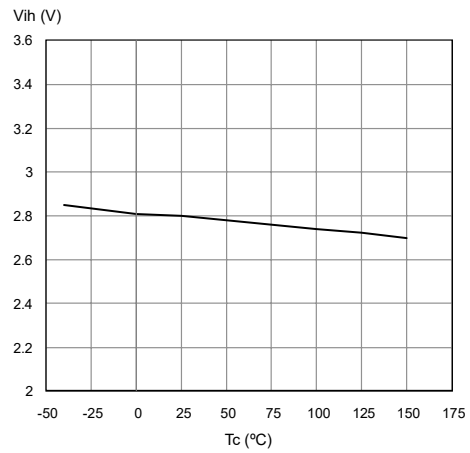

Input Low Level

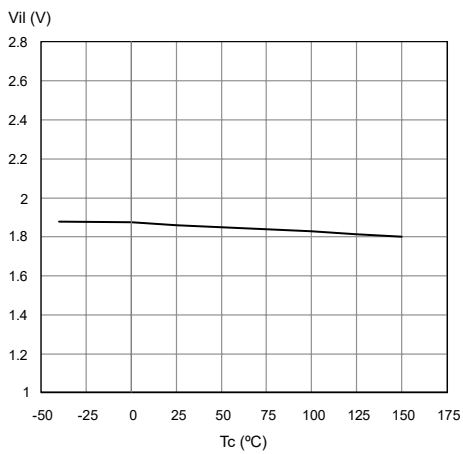

Input Hysteresis Voltage

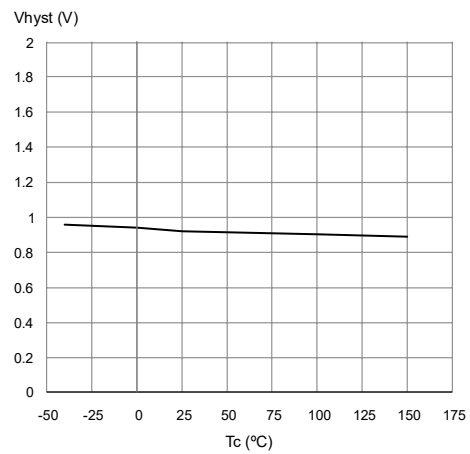

Overvoltage Shutdown

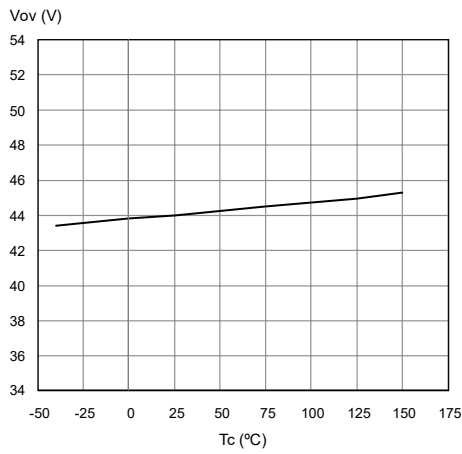

I_{LIM} Vs T_{case}

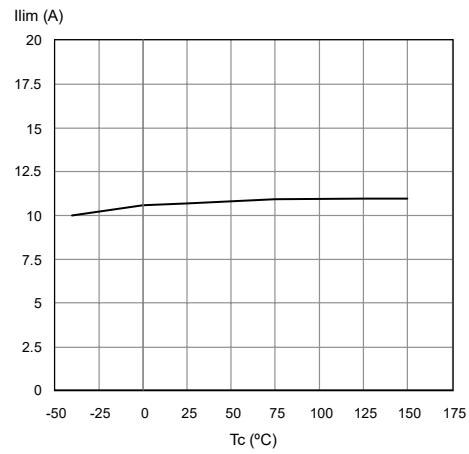

Turn-on Voltage Slope

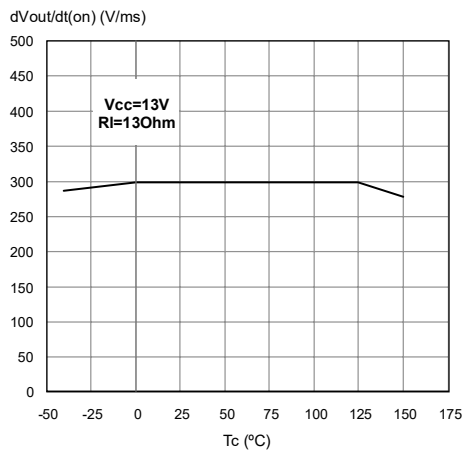

Turn-off Voltage Slope

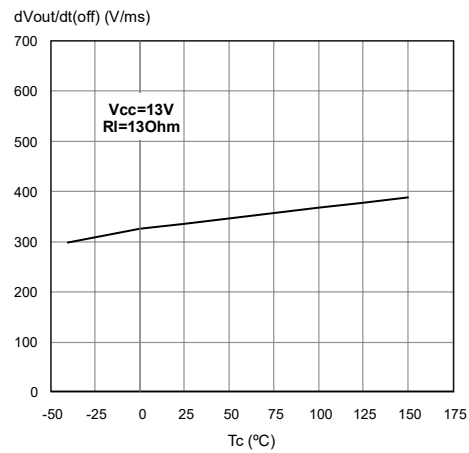

On State Resistance Vs T_{case}

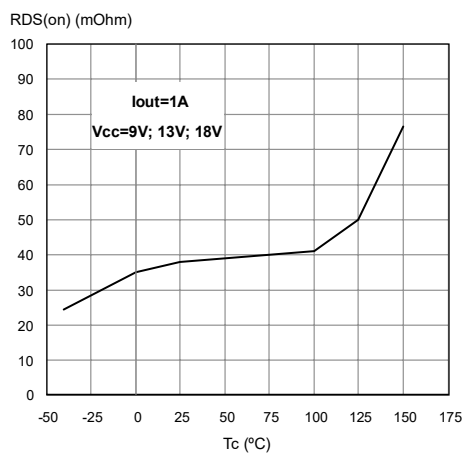

On State Resistance Vs V_{CC}

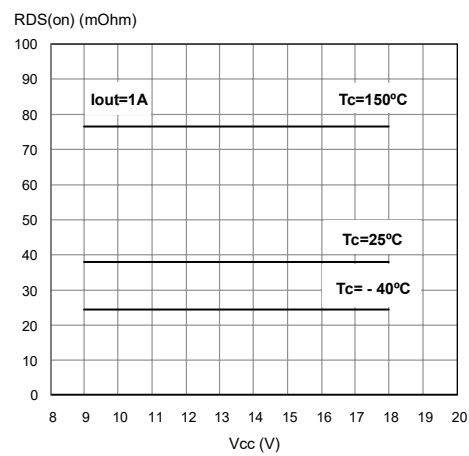

Status Clamp Voltage

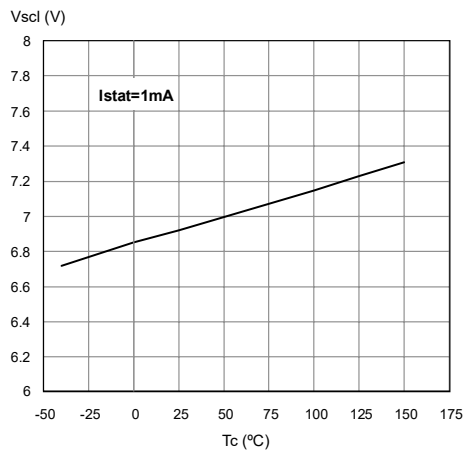

Status Leakage Current

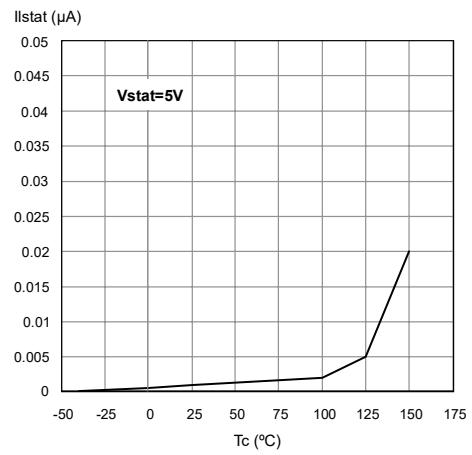

Status Low Output Voltage

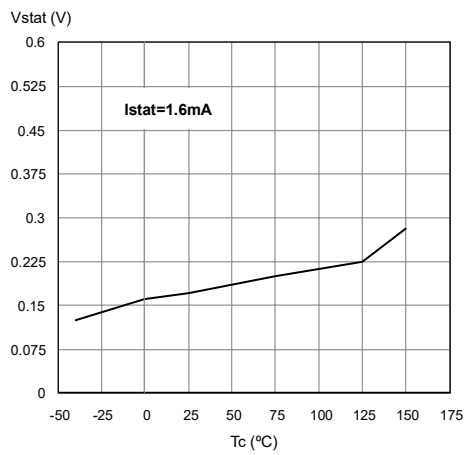

Open Load Off State Voltage Detection Threshold

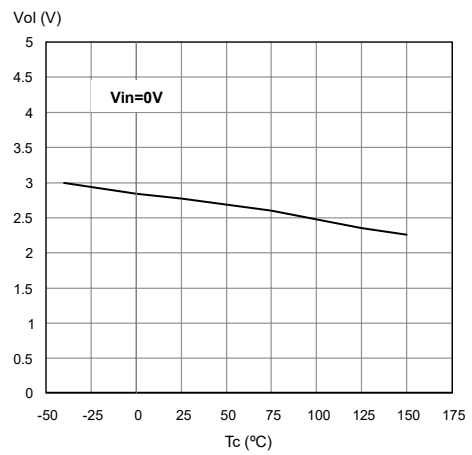

PowerSO-10 Maximum turn off current versus load inductance

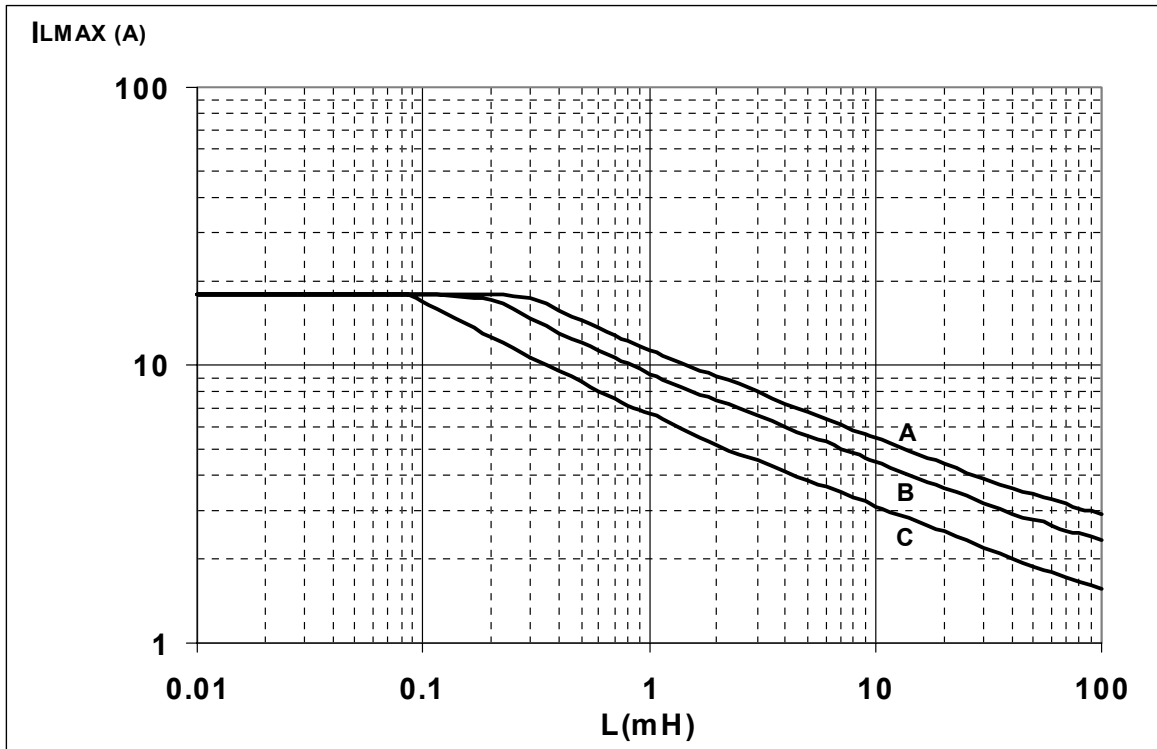

A = Single Pulse at $T_{Jstart}=150^{\circ}C$
 B = Repetitive pulse at $T_{Jstart}=100^{\circ}C$
 C = Repetitive Pulse at $T_{Jstart}=125^{\circ}C$

Conditions:

$V_{CC}=13.5V$

Values are generated with $R_L=0\Omega$

In case of repetitive pulses, T_{jstart} (at beginning of each demagnetization) of every pulse must not exceed the temperature specified above for curves B and C.

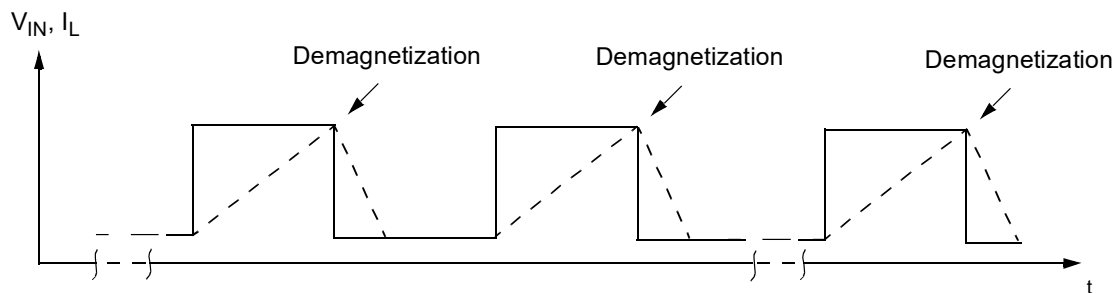

PowerSO-10™ THERMAL DATA

PowerSO-10™ PC Board

Layout condition of R_{th} and Z_{th} measurements (PCB FR4 area= 58mm x 58mm, PCB thickness=2mm, Cu thickness=35 μ m, Copper areas: from minimum pad lay-out to 8cm²).

$R_{thj-amb}$ Vs. PCB copper area in open box free air condition

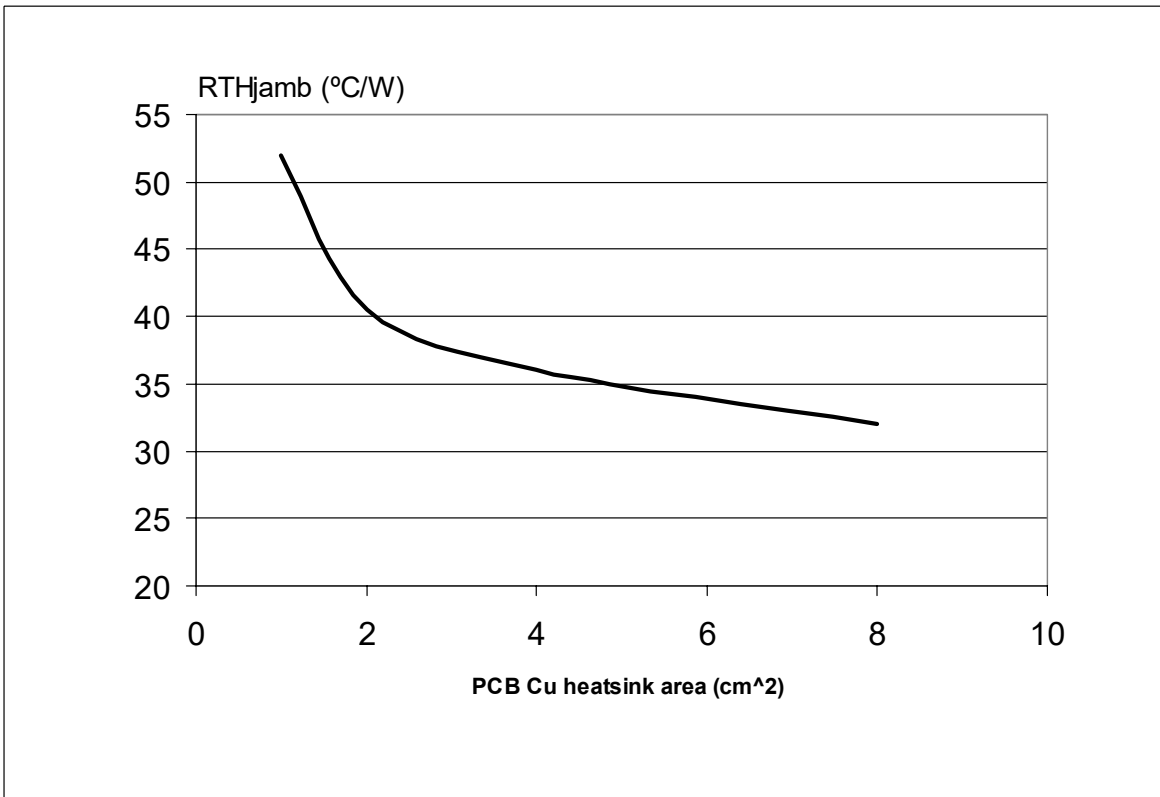

PowerSO-10 Thermal Impedance Junction Ambient Single Pulse

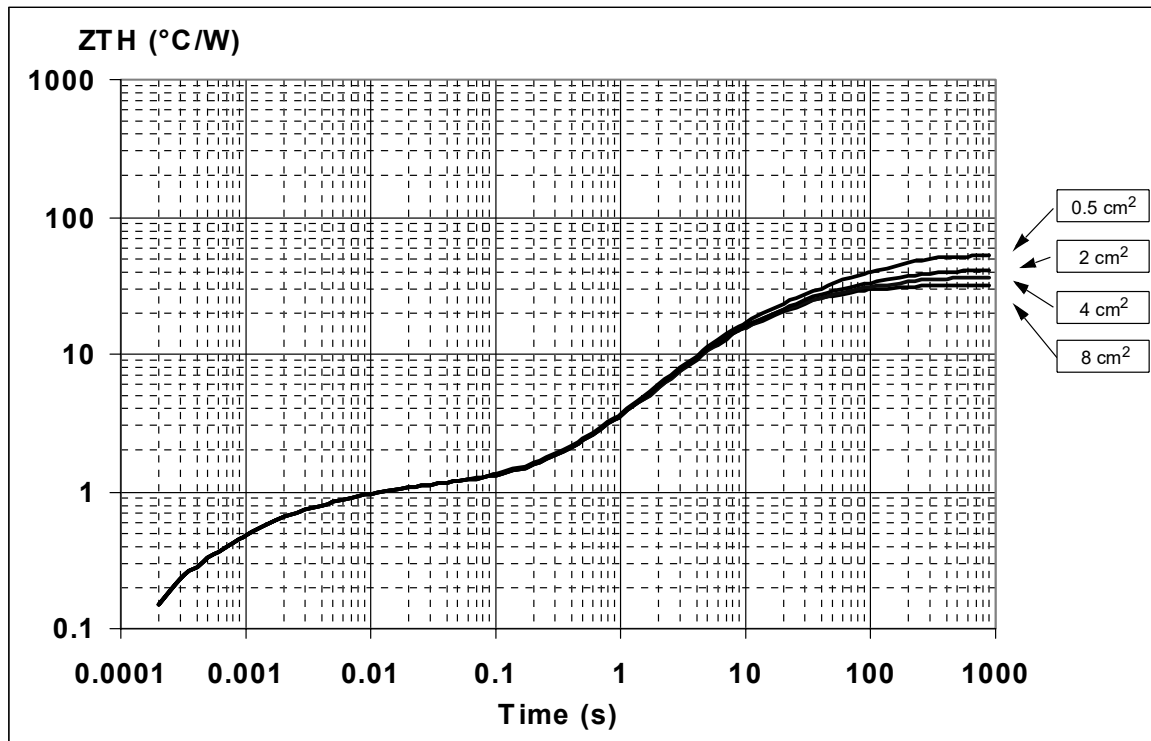

Thermal fitting model of a single channel HSD in PowerSO-10

Pulse calculation formula

$$Z_{TH\delta} = R_{TH} \cdot \delta + Z_{THtp}(1 - \delta)$$

where $\delta = t_p/T$

Thermal Parameter

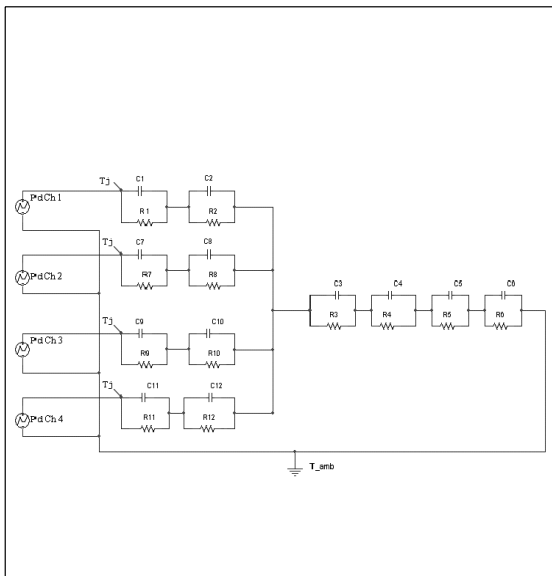

Area/island (cm ²)	0.5	2	4	8
R1=R7=R9=R11 (°C/W)	0.15			
R2=R8=R10=R12 (°C/W)	0.5			
R3 (°C/W)	0.4			
R4 (°C/W)	10			
R5 (°C/W)	15			
R6 (°C/W)	26	14.5	10	6
C1=C7=C9=C11 (W.s/°C)	0.0006			
C2=C8=C10=C12 (W.s/°C)	0.0021			
C3 (W.s/°C)	0.02			
C4 (W.s/°C)	0.5			
C5 (W.s/°C)	1.5			
C6 (W.s/°C)	5	10	14	18

PowerSO-10™ MECHANICAL DATA

DIM.	mm.			inch		
	MIN.	TYP	MAX.	MIN.	TYP.	MAX.
A	3.35		3.65	0.132		0.144
A (*)	3.4		3.6	0.134		0.142
A1	0.00		0.10	0.000		0.004
B	0.40		0.60	0.016		0.024
B (*)	0.37		0.53	0.014		0.021
C	0.35		0.55	0.013		0.022
C (*)	0.23		0.32	0.009		0.0126
D	9.40		9.60	0.370		0.378
D1	7.40		7.60	0.291		0.300
E	9.30		9.50	0.366		0.374
E2	7.20		7.60	0.283		300
E2 (*)	7.30		7.50	0.287		0.295
E4	5.90		6.10	0.232		0.240
E4 (*)	5.90		6.30	0.232		0.248
e		1.27			0.050	
F	1.25		1.35	0.049		0.053
F (*)	1.20		1.40	0.047		0.055
H	13.80		14.40	0.543		0.567
H (*)	13.85		14.35	0.545		0.565
h		0.50			0.002	
L	1.20		1.80	0.047		0.070
L (*)	0.80		1.10	0.031		0.043
α	0°		8°	0°		8°
α (*)	2°		8°	2°		8°

(*) Muar only POA P013P

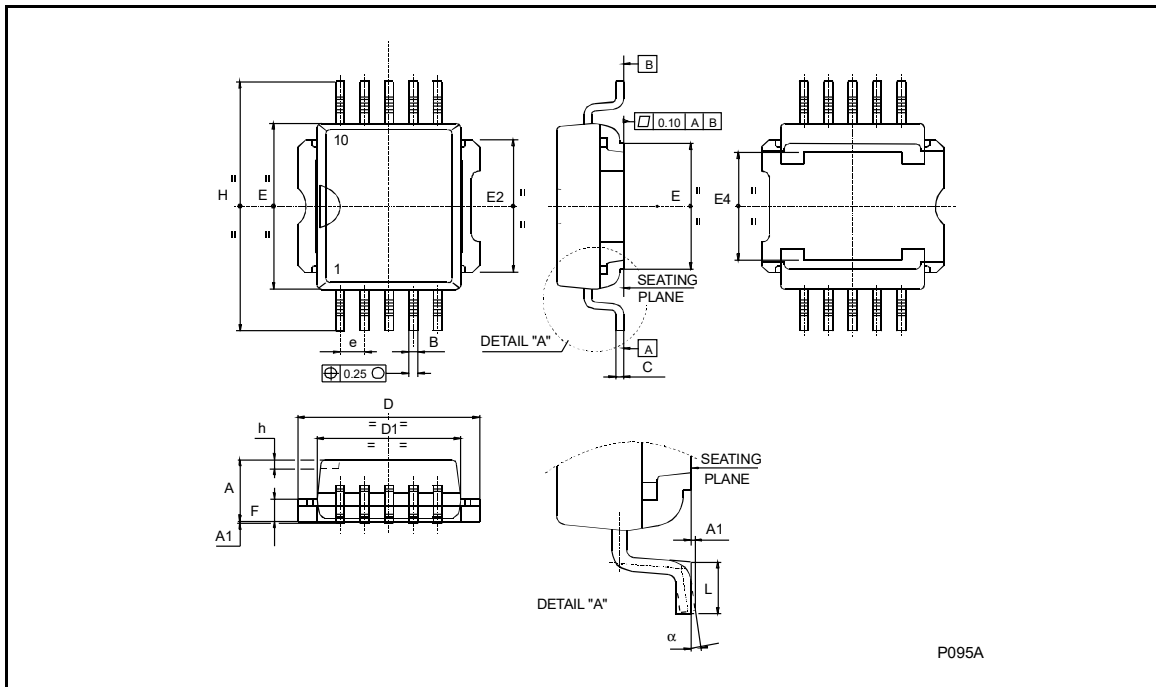

PowerSO-10™ SUGGESTED PAD LAYOUT

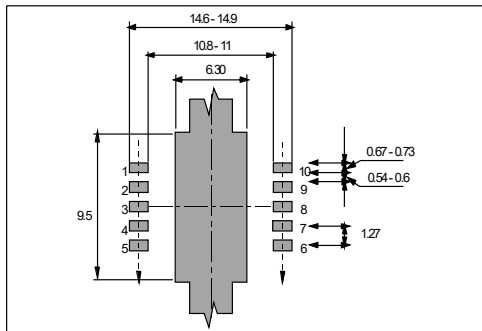

TUBE SHIPMENT (no suffix)

All dimensions are in mm.

	Base Q.ty	Bulk Q.ty	Tube length (± 0.5)	A	B	C (± 0.1)
Casablanca	50	1000	532	10.4	16.4	0.8
Muar	50	1000	532	4.9	17.2	0.8

TAPE AND REEL SHIPMENT (suffix "13TR")

40mm min. Access hole at slot location

Full radius

Tape slot in core for tape start 2.5mm min. width.

G measured at hub

REEL DIMENSIONS

Base Q.ty	600
Bulk Q.ty	600
A (max)	330
B (min)	1.5
C (± 0.2)	13
F	20.2
G (+ 2 / -0)	24.4
N (min)	60
T (max)	30.4

All dimensions are in mm.

TAPE DIMENSIONS
According to Electronic Industries Association (EIA) Standard 481 rev. A, Feb. 1986

Tape width	W	24
Tape Hole Spacing	P0 (± 0.1)	4
Component Spacing	P	24
Hole Diameter	D (± 0.1/-0)	1.5
Hole Diameter	D1 (min)	1.5
Hole Position	F (± 0.05)	11.5
Compartment Depth	K (max)	6.5
Hole Spacing	P1 (± 0.1)	2

All dimensions are in mm.

TOP COVER TAPE

User Direction of Feed

End

Start

No components

Components

No components

500mm min

500mm min

Empty components pockets sealed with cover tape.

User direction of feed

REVISION HISTORY

Date	Revision	Description of Changes
Jul 2004	1	<ul style="list-style-type: none">- Minor changes- Current and voltage convention update (page 2).- "Configuration diagram (top view) & suggested connections for unused and n.c. pins" insertion (page 3).- 6 cm² Cu condition insertion in Thermal Data table (page 3).- V_{CC} - OUTPUT DIODE section update (page 3).- PROTECTIONS note insertion (page 4)- Revision History table insertion (page 18).- Disclaimers update (page 19).
Jul 2004	2	<ul style="list-style-type: none">- Disclaimers update (page 19).

Information furnished is believed to be accurate and reliable. However, STMicroelectronics assumes no responsibility for the consequences of use of such information nor for any infringement of patents or other rights of third parties which may result from its use. No license is granted by implication or otherwise under any patent or patent rights of STMicroelectronics. Specifications mentioned in this publication are subject to change without notice. This publication supersedes and replaces all information previously supplied. STMicroelectronics products are not authorized for use as critical components in life support devices or systems without express written approval of STMicroelectronics.

The ST logo is a trademark of STMicroelectronics.
All other names are the property of their respective owners

© 2004 STMicroelectronics - Printed in ITALY- All Rights Reserved.

STMicroelectronics GROUP OF COMPANIES

Australia - Belgium - Brazil - Canada - China - Czech Republic - Finland - France - Germany - Hong Kong - India - Israel - Italy - Japan -
Malaysia - Malta - Morocco - Singapore - Spain - Sweden - Switzerland - United Kingdom - United States
<http://www.st.com>